

**How to measure for your new ISP-1026 "Clamp On/Ready to Install"
Lateral Drag Head Supports**

Measurement #1 (Head Support Length, Left Side)

At center of drivers left ear when seated in car (approximately same height as left helmet bar) measure in a straight line from front roll bar hoop to the point where the helmet bar begins to curve behind the drivers head. This measurement is used to determine overall support length. This style of support does not wrap behind helmet. A separate rear SFI 45.2 pad 'ISP-1010B' is available for an additional cost.

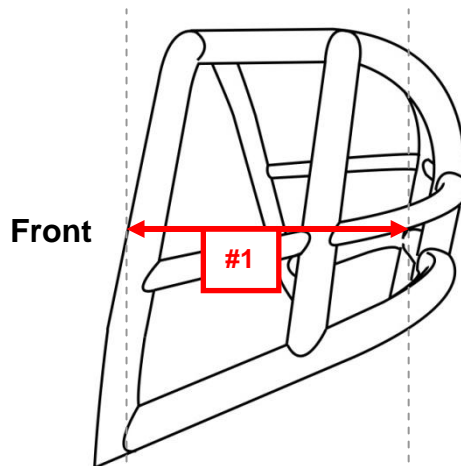
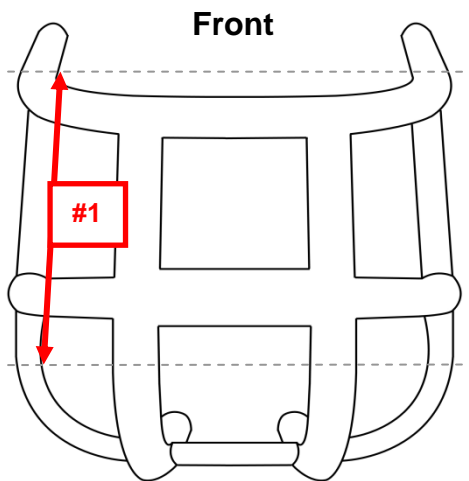

Enter Measurement
#1 here (Left Side)

Measurement #2 (Split Clamp Spacing, Left Side)

At center of drivers left ear when seated in car (approximately same height as left helmet bar) measure in a straight line from **rear** of front left roll bar hoop to the point where the helmet bar connects to the left center roll bar hoop. This measurement is required to determine proper left side split clamp front to rear spacing as well as distance between left side split clamps.

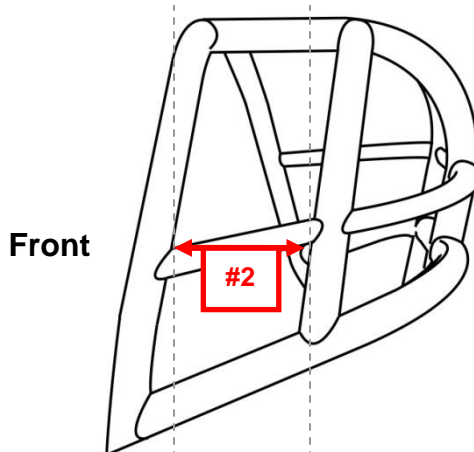
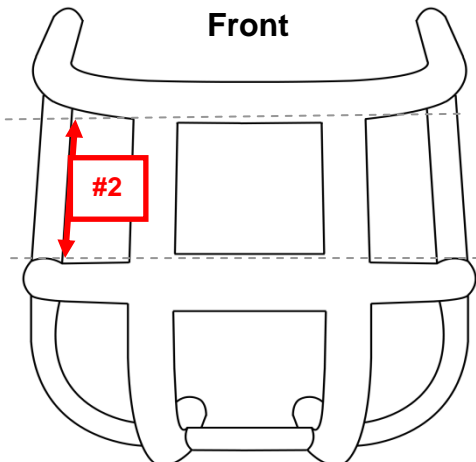

Enter Measurement
#2 here (Left Side)

Measurement #3 (Head Support Length Right Side)

At center of drivers left ear when seated in car (approximately same height as right helmet bar) measure in a straight line from front roll bar hoop to the point where the helmet bar begins to curve behind the drivers head. This measurement is used to determine overall support length. This style of support does not wrap behind helmet. A separate rear SFI 45.2 pad 'ISP-1010B' is available for an additional cost.

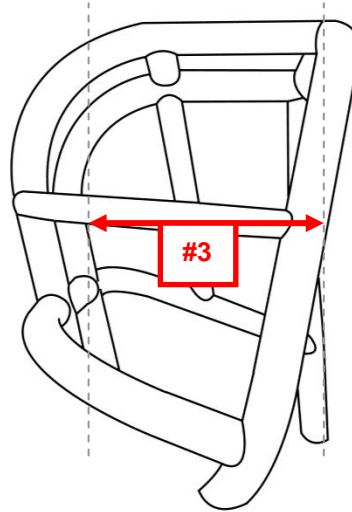
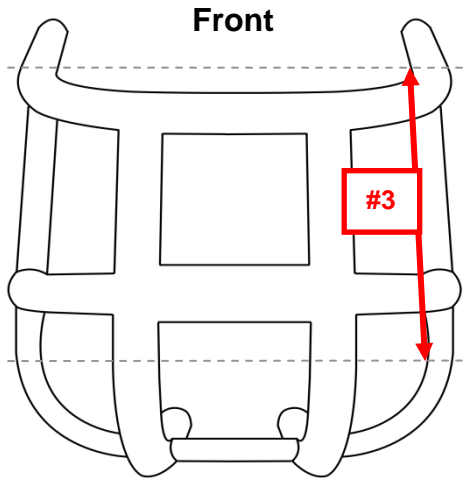

Enter Measurement
#3 here (Right Side)

Measurement #4 (Split Clamp Spacing Right Side)

At center of drivers right ear when seated in car (approximately same height as right helmet bar) measure in a straight line from **rear** of front right roll bar hoop to the point where the helmet bar connects to the right center roll bar hoop. This measurement is required to determine proper right side split clamp front to rear spacing as well as distance between right side split clamps. If your chassis does not have a center hoop on the right side please use measurement from left side step #2

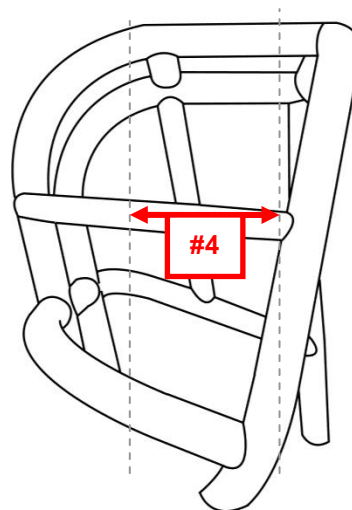
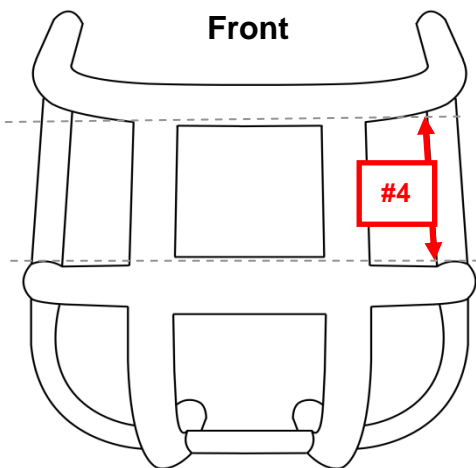

Enter Measurement
#4 here (Right Side)

Measurement #5 (Support Height, Left Only)

With driver seated in car determine what line below best represents height of the center left ear in relation to the helmet bar. **A** = Above, **B** = Center and **C** = Below (This will allow us to determine the proper left side support height to provide the best protection)

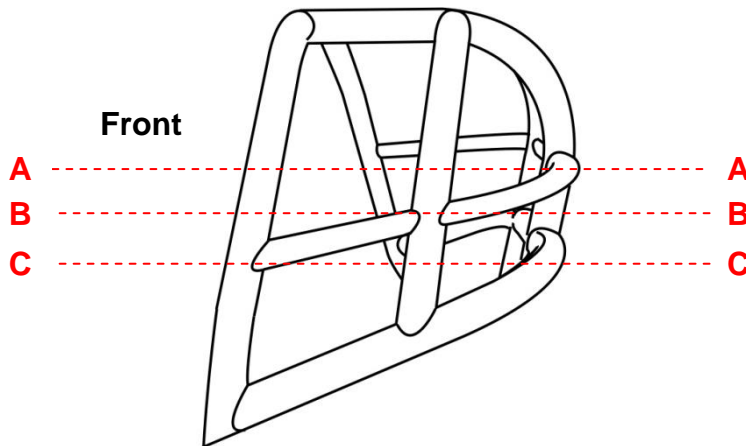

Enter Measurement
#5 here (Left Side)

Measurement #6 (Support Height, Right Only)

With driver seated in car determine what line below best represents height of the center right ear in relation to the helmet bar. **A** = Above, **B** = Center and **C** = Below (This will allow us to determine the proper left side support height to provide the best protection)

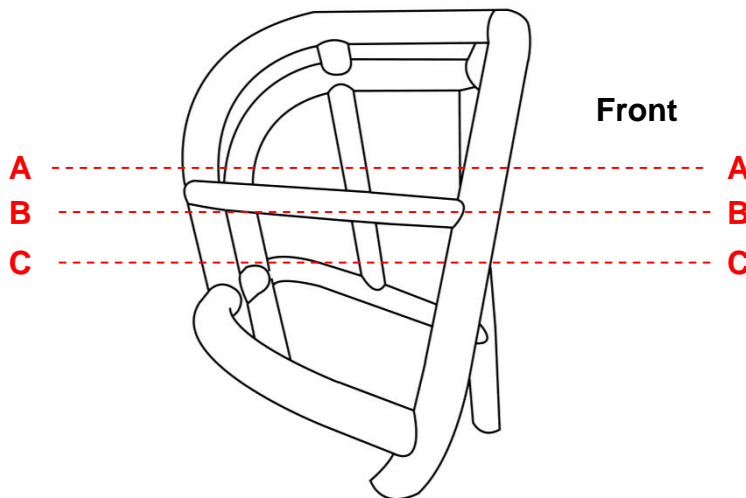

Enter Measurement
#6 here (Right Side)

Measurement #7 (Front Hoop Angle, Left Only)

Using an angle finder measure the angle of the front left side roll bar hoop, determine the angle of the front cage hoop this should be represented in degrees. This measurement must be correct to prevent the support from extending beyond cage front hoop and snagging fire suit. To ensure accuracy please select the appropriate letter to indicate the direction the front left hoop leans either to the **F**ront or to the **R**ear

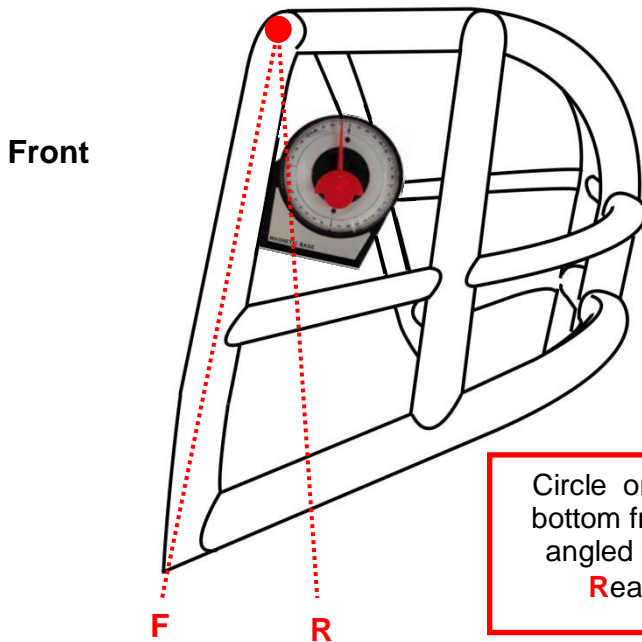

Enter Measurement **#7** here (Left Side)

Circle on drawing if bottom front hoop is angled to **F**ront or **R**ear of car

Measurement #8 (Front Hoop Angle, Right Only)

Using an angle finder measure the angle of the front right side roll bar hoop, determine the angle of the front cage hoop this should be represented in degrees. This measurement must be correct to prevent the support from extending beyond cage front hoop and snagging fire suit. To ensure accuracy please select the appropriate letter to indicate the direction the front left hoop leans either to the **F**ront or to the **R**ear

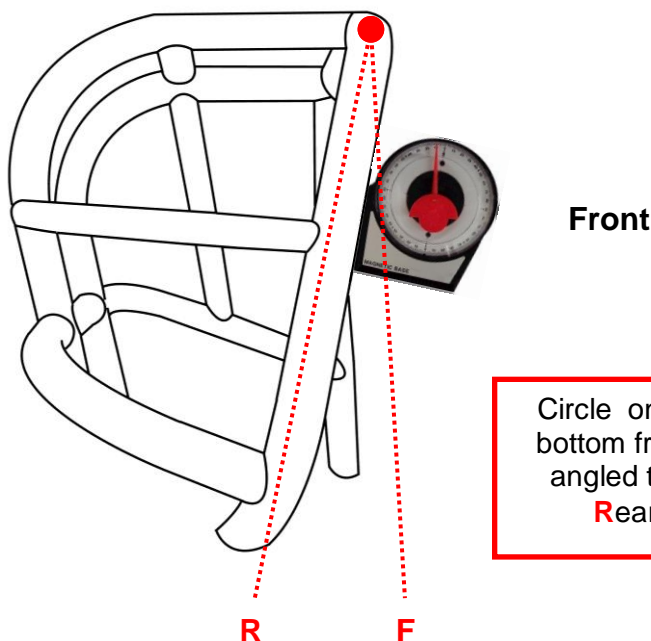

Enter Measurement **#8** here (Right Side)

Circle on drawing if bottom front hoop is angled to **F**ront or **R**ear of car

Measurement #9 (Helmet Bar Inset, Left Only)

Using a straight edge across the front hoop and the middle hoop to determine if the helmet bar is flush mounted to the interior of cage or if it is inset. If helmet bar is inset measure from the straight edge to the helmet bar.

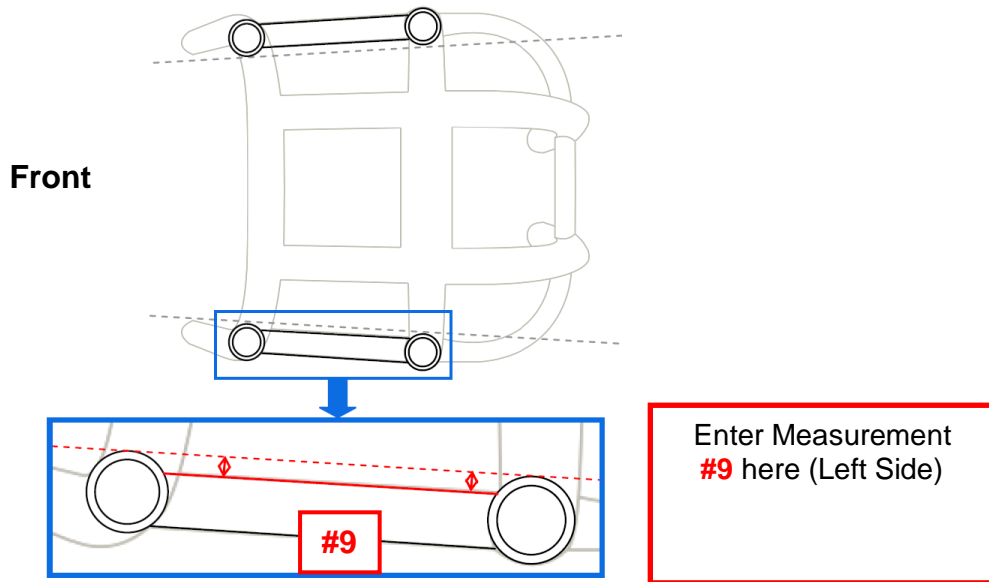

Measurement #9 (Helmet Bar Inset, Right Only)

Using a straight edge across the front hoop and the middle hoop please determine if the helmet bar is flush mounted to the interior of cage or if it is inset. If helmet bar is inset measure from the straight edge to the helmet bar.

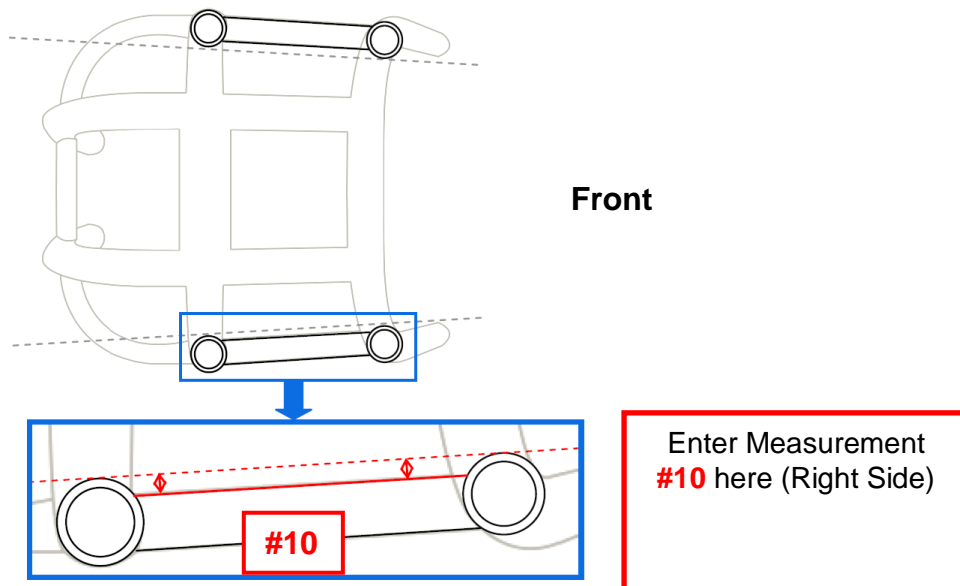



5540 Morehead Rd.
 Harrisburg, NC 28075 USA
 P: 704.455.3060
 F: 704.455.2009
 kris@ispseats.com
ispseats.com

Measurements #11 and #12 (Padding Thickness Left and Right Side)

Please indicate in inches how much padding you would like on the left side, be sure to sit in car and position head as if you were staging and looking at light for measurement #9 thickness. Repeat process with head leaning to the right as if you were staging to obtain measurement #10 thickness. In both measurements be certain to emulate the worst case scenario of head positions for viewing the tree and or you competitor.

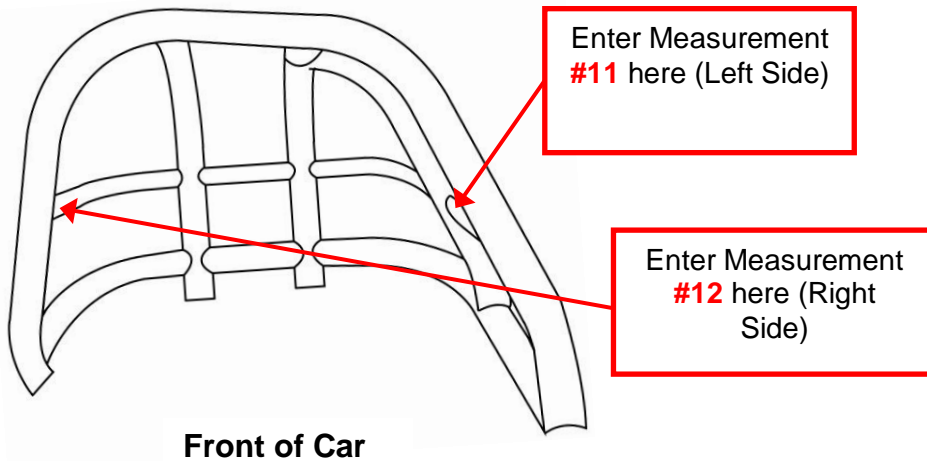

To begin the order process:

Fax all three pages of this completed form to **704.455.2009**

Within one business day you will receive call from ISP for billing and shipping information.

If possible please follow up with an email to kris@ispseats.com and include images of the driver and or any specific concerns.

Print Name: _____ Daytime Ph. Number: _____

Helmet Bar Tubing Diameter (Circle one): **3/4** Inch or **1** Inch

Measurements from above: #1 (_____) #2 (_____) #3 (_____) #4 (_____) #5 (_____)

#6 (_____) #7 (_____) #8 (_____) #9 (_____) #10 (_____) #11 (_____) #12 (_____)

Chassis Manufacturer: _____ Chassis Type: _____